

# ECP200 BASE 2 / 4



---

*Use and maintenance manual*

---

**READ AND KEEP**

## ENGLISH

**INTRODUCTION****CHAP. 1**

Pag. 3	1.1	General
Pag. 4	1.2	Product ID codes
Pag. 4	1.3	Overall dimensions
Pag. 5	1.4	Identification data

**INSTALLATION****CHAP. 2**

Pag. 5	2.1	Important information for the installer
Pag. 5	2.2	Standard assembly kit
Pag. 6	2.3	Installing the unit

**TECHNICAL CHARACTERISTICS****CHAP. 3**

Pag. 7	3.1	Technical characteristics
--------	-----	---------------------------

**WARRANTY****CHAP. 4**

Pag. 8	4.1	Warranty
--------	-----	----------

**PARAMETER PROGRAMMING****CHAP. 5**

Pag. 9	5.1	Control panel
Pag. 9	5.2	Frontal keypad
Pag. 10	5.3	LED display
Pag. 11	5.4	General
Pag. 11	5.5	Key to symbols
Pag. 11	5.6	Setting and displaying set points
Pag. 12	5.7	Level 1 programming
Pag. 12	5.8	List of Level 1 variables
Pag. 13	5.9	Level 2 programming
Pag. 13	5.10	List of Level 2 variables
Pag. 15	5.11	Switching on the ECP200 BASE electronic controller
Pag. 15	5.12	Compressor activation/deactivation conditions
Pag. 15	5.13	Manual defrosting
Pag. 16	5.14	Hot gas defrosting
Pag. 16	5.15	Pump down function
Pag. 16	5.16	Password protection

**OPTION****CHAP. 6**

Pag. 17	6.1	<i>TeleNET</i> monitoring / supervision system
Pag. 17	6.2	Net configuration with Modbus-rtu protocol
Pag. 18	6.3	ALARM RELAY / RS485 switching

**TROUBLESHOOTING****CHAP. 7**

Pag. 19	7.1	Troubleshooting
---------	-----	-----------------

**APPENDICES**

Pag. 20	A.1	EC declaration of conformity
Pag. 21	A.2	ECP200 BASE 4 wiring diagram
Pag. 21	A.3	ECP200 BASE 4A wiring diagram
Pag. 22	A.4	ECP200 BASE 2 wiring diagram
Pag. 22	A.5	ECP200 BASE 2A wiring diagram
Pag. 23	A.6	Connection example (1) - ECP200 BASE4 /BASE4A
Pag. 23	A.7	Connection example (2) - ECP200 BASE4 /BASE4A
Pag. 24	A.8	Connection example (3) - ECP200 BASE2 /BASE2A
Pag. 24	A.9	Connection example (4) - ECP200 BASE2 /BASE2A

# CHAPTER 1: INTRODUCTION

## GENERAL

1.1

### DESCRIPTION:

The **ECP200 BASE** is a new control panel for cold rooms with a single-phase compressor up to 2 HP, specially designed to provide the user with safety, protection, control and ease of installation.

It allows the user to control all the components on a refrigerating system: compressor, evaporator fans, defrosting elements, room light and thermostat-holder demisting element.

### APPLICATIONS:

- Complete management of single-phase static or ventilated refrigeration systems up to 2 HP, with off-cycle or electrical defrosting and with direct or pump-down compressor stop.
- Control of single-phase evaporator unit only with freon solenoid enable signal or remote condensing unit enable signal.

### MAIN CHARACTERISTICS:

- Cold room temperature displaying and regulation with decimal point
- Evaporator temperature displaying from parameter
- Plant control activation/deactivation
- Plant alarms signaling (probe error, minimum and maximum temperature alarm, compressor protection)
- LED indicators and large display illustrate system status.
- User-friendly keypad.
- Evaporator fans management
- Manual and automatic defrost (static, through heaters, through cycle reversal)
- Direct or pump-down management and control of condensing unit up to 2HP
- Cold room light activation through key on the panel or through door-switch
- Direct control of compressor, defrosting elements, evaporator fans, room light with outputs directly connectable to the various units.
- Auxiliary relay with parameter-configured
- Possibility, as an alternative to an auxiliary relay, of a RS485 port for connection to the TeleNET supervision net or to a net with MODBUS-RTU protocol.

## 1.2

## PRODUCT ID CODES

**ECP200 BASE 2**

controls and manages compressor and room light.

**ECP200 BASE 2 A**

controls and manages compressor and room light. Alarms relay.

**ECP200 BASE 4**

controls and manages compressor, defrosting elements, evaporator fans and room light.

**ECP200 BASE 4 A**

controls and manages compressor, defrosting elements, evaporator fans and room light. Alarms relay.

## 1.3

## OVERALL DIMENSIONS



## IDENTIFICATION DATA

1.4

The unit described in this manual has an ID plate on the side showing all the relevant identification data:

- Name of Manufacturer
- Code and model of unit electrical board
- Serial number
- Date
- Power supply
- Rated current
- IP protection rating

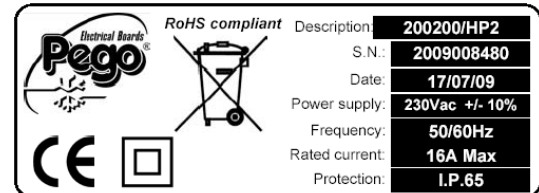

## CHAPTER 2: INSTALLATION

## IMPORTANT INFORMATION FOR THE INSTALLER

2.1

1. Install the device in places where the protection rating is observed and try not to damage the box when drilling holes for wire/pipe seats.
2. Do not use multi-polar cables in which there are wires connected to inductive/power loads or signalling wires (e.g. probes/sensors and digital inputs).
3. Do not fit power supply wiring and signal wiring (probes/sensors and digital inputs) in the same raceways or ducts.
4. Minimise the length of connector wires so that wiring does not twist into a spiral shape as this could have negative effects on the electronics.
5. Fit a general protection fuse upstream from the electronic controller.
6. All wiring must be of a cross-section suitable for relevant power levels.
7. When it is necessary to make a probe/sensor extension, the wires must have a cross-section of at least 1 mm<sup>2</sup>. Probes extension or shortening could alter their factory calibration; therefore to check and calibrate the probes through an external thermometer.

## STANDARD ASSEMBLY KIT

2.2

For the purposes of assembly and use, the electronic **ECP200 BASE** control unit comes with:

- N° 3 seals, to be fitted between the fixing screws and the box back panel
- N° 1 user's manual.

## 2.3

## INSTALLING THE UNIT

**Fig. 1 :** Undo the 4 screws on the front of the panel.



**Fig. 2 :** Use the three existing holes to fix the box back panel to the wall: use three screws of a length suitable for the thickness of the wall to which the panel will be attached. Fit a rubber washer (supplied) between each screw and the box backing.

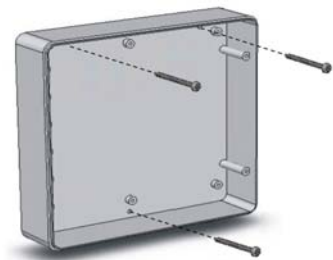

Make all the electrical connections as illustrated in the diagram for the corresponding model (see relative table in APPENDICES).

To effect correct electrical connection and maintain the protection rating, use appropriate wire/raceway grips to ensure a good seal.

Route the wiring inside the unit in as tidy a fashion as possible: be especially careful to keep power wires away from signal wires. Use clips to hold wires in place.



**Fig. 4 :** close the front panel, making sure that all the wires are inside the box and that the box seal sits in its seat properly.

Tighten the front panel using the 4 screws, making sure the O-rings on the head of each screw are used.

Power up the panel and carry out thorough reading/programming of all the parameters.



Be careful not to over-tighten the closure screws as this could warp the box and compromise proper operation of the membrane-type keypad.

Install short-circuit overload safety devices on all the power cables connected to the ECP200 controller so as to prevent damage to the device. Work and/or maintenance must ONLY be carried out on the unit after disconnecting the panel from the power supply and from any inductive/power loads: doing so allows the worker to do his job safely.



# CHAPTER 3: TECHNICAL CHARACTERISTICS

## TECHNICAL CHARACTERISTICS

3.1

<b>Power supply</b>				
Voltage		230 V~ ± 10% 50Hz / 60Hz		
Max power (only electronics)		~ 7 VA		
Rated current (With all loads connected)		16A		
<b>Climatic conditions</b>				
Working temperature		-5 ÷ +50°C		
Storage temperature		-10 ÷ +70°C		
Relative ambient humidity		Lower than 90% Hr		
<b>General characteristics</b>				
Type of sensors that can be connected		NTC 10K 1%		
Resolution		0,1 °C.		
Sensor read precision		± 0,5 °C		
Read range		-45 ÷ +45 °C		
<b>Output characteristics (free voltage contact)</b>				
Description	Installed relay	Card output characteristics	BASE 2	BASE4
Compressor	(Relay 30A AC1)	10A 250V~ (AC3) (2HP) (100000 cycles)	X	X
Elements	(Relay 30A AC1)	16A 250V~ (AC1)		X
Fans	(Relay 16A AC1)	2,7A 250V~ (AC3)		X
Room light	(Relay 16A AC1)	16A 250V~ (AC1)	X	X
Alarm / Aux (Optional)	(Relay 8A AC1)	8(3)A 250V~	X optional	X optional
<b>Dimensional characteristics</b>				
Dimensions		19.3cm x 7.9cm x 20.3cm (HxPxL)		
<b>Dimensions</b>				
Box protection rating		IP65		
Box material		ABS autoestinguente		
Type of insulation		Class II		

## CHAPTER 4: WARRANTY

### 4.1

### WARRANTY

ECP200 BASE series products are covered by a 24-month warranty against all manufacturing defects as from the date indicated on the product ID code or from the date of product registration card, if present.

In the event of a defect the product must be appropriately packaged and sent to our factory or any authorized Service Center by authority RMA number received.

Customers are entitled to have defective products repaired, spare parts and labour included. Transport expenses and risk shall be met entirely by the customer.

Repairs carried out under warranty do not prolong or renew the warranty expiration date.

The Warranty does not cover:

- Damages resulting from tampering, impact or improper installation of humidifier and its accessories.
- Behaviour inconsistent with Manufacturer's prescriptions and instructions.
- Damages caused by repairs made by unauthorized persons.
- Damages caused by natural phenomena as lightning, natural calamities, etc.

Warranty cover may be refused if the device is modified or changed.

Under no circumstances **Pego S.r.l.** will be responsible for possible loss of data and information, costs of substitutive goods or services, damages to things, people or animals, non-sale or non-gain, activity interruption, possible direct, indirect, accidental, property, covering, punitive, special or consequential damages anyhow caused, whether they are contractual, extra-contractual or due to negligence or other responsibility, derived from product use or from its installation.

The wrong machine working caused by manumissions, shoves, inadequate installation automatically forfeits the warranty right. It is compulsory to respect all information of this user manual and device operating conditions.

**PEGO S.r.l.** declines any responsibility for possible errors or inaccuracies written in this manual as a result of printing or transcription errors.

**PEGO S.r.l.** reserves the right to modify its products as it deems necessary without altering its main characteristics.

Each new release of a PEGO user manual replaces all the previous ones.

However not expressly indicated, the warranty follows the laws in force and particularly the section 1512 C.C. (Italian Civil Code)

For any controversy is elected by the parties and recognized the jurisdiction of the Court of Rovigo.



# CHAPTER 5: PARAMETER PROGRAMMING



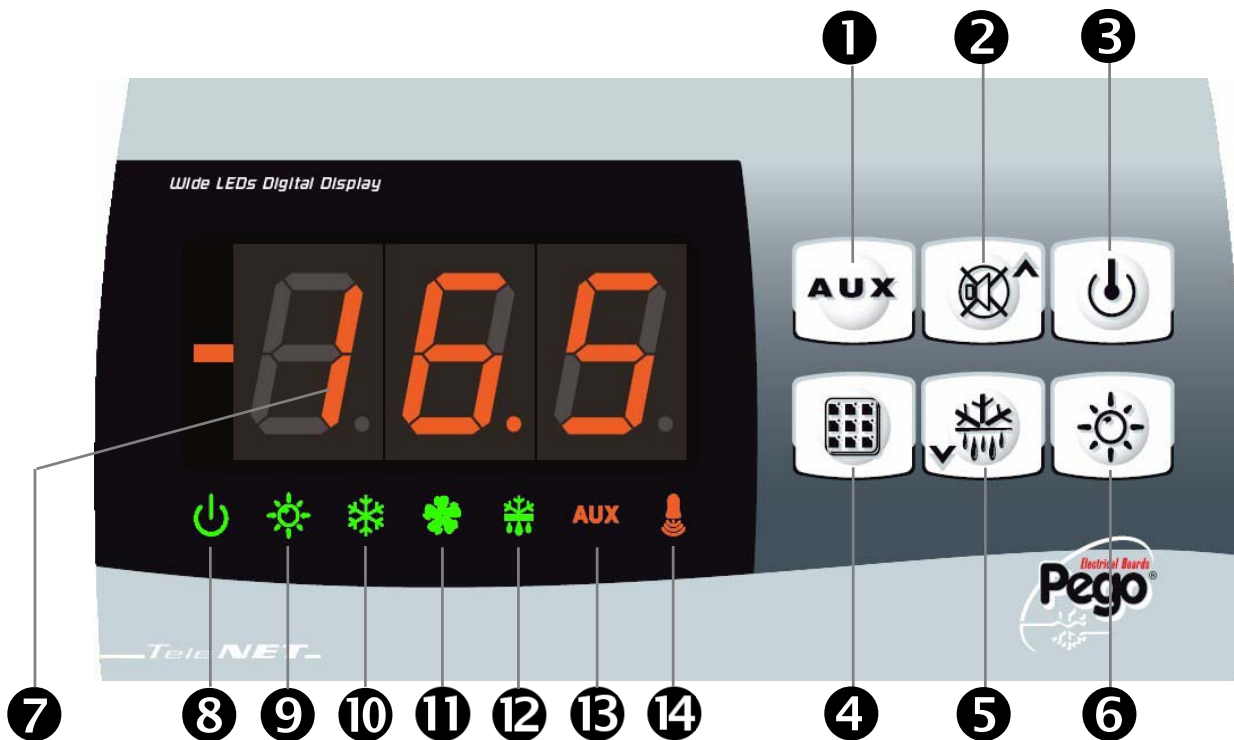

## CONTROL PANEL

5.1



## FRONT KEYPAD







5.2

- 1

**AUXILIARY RELAY CONTROL** (on the version with alarm relay controls the relay manual if parameter AU=1)
- 2

**UP / MUTE BUZZER ALARM**
- 3

**STAND BY** (if the system shuts down the LED flashes)
- 4

**room temperature SETTING**

- 5  DOWN / MANUAL DEFROST
- 6  ROOM LIGHT

## 5.3

## LED DISPLAY

- 7 Cold room temperature / parameters
- 8  Stand-by (flashes on stand-by. Outputs are deactivated)
- 9  Room light (flashes if door switch activated)
- 10  Cold (indicates activation of compressor)
- 11  Fans
- 12  Defrosting
- 13 **AUX** Ausiliary
- 14  Alarm/warning

## GENERAL

5.4



To enhance safety and simplify the operator's work, the **ECP200 EXPERT** has two programming levels; the first level (Level 1) is used to configure the frequently-modified **SETPOINT** parameters. The second programming level (Level 2) is for general parameter programming of the various controller work modes.

It is not possible to access the Level 2 programming directly from Level 1: you must exit the programming mode first.

## KEY TO SYMBOLS

5.5

For purposes of practicality the following symbols are used:

- (▲) the UP key  is used to increase values and mute the alarm.
- (▼) the DOWN key  is used to decrease values and force defrosting.

## SETTING AND DISPLAYING THE SET POINTS

5.6

1. Press the **SET key** to display the current **SETPOINT** (temperature)
2. Hold down the **SET key** and press the (▲) or (▼) keys to modify the **SETPOINT**.  
Release the **SET key** to return to cold room temperature display: the new setting will be saved automatically.

## 5.7

## LEVEL 1 PROGRAMMING (User level)

To gain access to the Level 1 configuration menu proceed as follows:

1. Press the (▲) and (▼) keys simultaneously and keep them pressed for a few seconds until the first programming variable appears on the display.
2. Release the (▲) and (▼) keys.
3. Select the variable to be modified using the (▲) or (▼) key.
4. When the variable has been selected it is possible:
  - to display the setting by pressing SET key
  - to modify the setting by pressing the SET key together with the (▲) or (▼) key.

When configuration values have been set you can exit the menu by pressing the (▲) and (▼) keys simultaneously for a few seconds until the cold room temperature reappears.

5. The new settings are saved automatically when you exit the configuration menu.

## 5.8

## LIST OF LEVEL 1 VARIABLES (User level)

VARIABLES	MEANING	VALUE	DEFAULT
<i>r0</i>	<b>Temperature difference</b> compared to main SETPOINT	0.2 - 10 °C	2°C
<i>d0</i>	<b>Defrost interval</b> (hours)	0 - 24 hours	4 hours
<i>d2</i>	<b>End-of-defrost setpoint.</b> Defrost is not executed if the temperature read by the defrost sensor is greater than <i>d2</i> (If the sensor is faulty defrosting is timed)	-35 - 45 °C	15°C
<i>d3</i>	<b>Max defrost duration</b> (minutes)	1 - 240 min	25 min
<i>d7</i>	<b>Drip duration</b> (minutes) At the end of defrost the compressor and fans remain at standstill for time <i>d7</i> , the defrost LED on the front panel flashes.	0 - 10 min	0 min
<i>F5</i>	<b>Fan pause</b> after defrost (minutes) Allows fans to be kept at standstill for a time <i>F5</i> after dripping. This time begins at the end of dripping. If no dripping has been set the fan pause starts directly at the end of defrost.	0 - 10 min	0 min
<i>A1</i>	<b>Minimum temperature alarm</b> Allows user to define a minimum temperature for the room being refrigerated. Below value <i>A1</i> an alarm trips: the alarm LED flashes, displayed temperature flashes and the buzzer sounds to indicate the problem.	-	-45°C
<i>A2</i>	<b>Maximum temperature alarm</b> Allows user to define a maximum temperature for the room being refrigerated. Above value <i>A2</i> an alarm trips: the alarm LED flashes, displayed temperature flashes and the buzzer sounds to indicate the problem.	-	+45°C
<i>tEu</i>	<b>Evaporator sensor temperature display</b> (displays nothing if dE =1)	Displays evaporator temperature (displays nothing if dE =1)	read only

**LEVEL 2 PROGRAMMING (Installer level)****5.9**

To access the second programming level press the UP (▲) and DOWN (▼) keys and the LIGHT key simultaneously for a few seconds.

When the first programming variable appears the system automatically goes to stand-by.

1. Select the variable to be modified by pressing the UP (▲) and DOWN (▼) keys.

When the parameter has been selected it is possible to:

2. View the setting by pressing the SET key.

3. Modify the setting by holding the SET key down and pressing the (▲) or (▼) key.

4. When configuration settings have been completed you can exit the menu by pressing the (▲) and (▼) keys simultaneously and keeping them pressed until the room temperature reappears.

5. Changes are saved automatically when you exit the configuration menu.

6. Press the STAND-BY key to enable electronic control.

**LIST OF LEVEL 2 VARIABLES (Installer level)****5.10**

VARIABLES	MEANING	VALUES	DEFAULT
<b>AC</b>	<b>Door switch status (with door closed)</b>	0= normally open 1= normally closed	0
<b>F3</b>	<b>Fan status with compressor off</b>	0 = Fans run continuously 1 = Fans only run when compressor is working	1
<b>F4</b>	<b>Fan pause during defrost</b>	0 = Fans run during defrost 1 = Fans do not run during defrost	1
<b>dE</b>	<b>Sensor presence</b> If the evaporator sensor is disabled defrosts are carried out cyclically with period <i>d0</i> : defrosting ends when an external device trips and closes the remote defrost contact or when time <i>d3</i> expires.	0 = evaporator sensor present 1 = no evaporator sensor	0
<b>d1</b>	<b>Defrost type</b> , cycle inversion (hot gas) or with heater elements	1= hot gas 0= element	0
<b>Ad</b>	<b>Net address</b> for connection to TeleNET supervision system or Modbus	0 ÷ 31 (with AU=3) 1 ÷ 247 (with AU=7)	0

## CHAP. 5 - Parameter programming

<b>Ald</b>	<b>Minimum and maximum temperature signalling and alarm display delay</b>	1...240 min	120 min
<b>C1</b>	<b>Minimum time between shutdown and subsequent switching on of the compressor.</b>	0...15 min	0 min
<b>CAL</b>	<b>Cold room sensor value correction</b>	-10...+10	0
<b>Pc</b>	<b>Compressor protection contact status</b>	0 = NO 1 = NC	0 = NO
<b>doC</b>	<b>Compressor safety time for door switch:</b> when the door is opened the evaporator fans shut down and the compressor will continue working for time <b>doC</b> , after which it will shut down.	0...5 minuti	0
<b>tdo</b>	<b>Compressor restart time after door opening.</b> when the door is opened and after tdo time, it's setted back the normal functioning giving door open alarm (Ed) With tdo=0 the parameter is disabled.	0...240 min 0 = disabled	0
<b>Fst</b>	<b>FAN shutdown TEMPERATURE</b> The fans will stop if the temperature value read by the <b>evaporator</b> sensor is higher than this value.	-45...+45°C	+45°C
<b>Fd</b>	<b>Fst differential</b>	0...+10°C	2°C
<b>LSE</b>	<b>Minimum value attributable to setpoint.</b>	-45... HSE °C	-45°C
<b>HSE</b>	<b>Maximum value attributable to setpoint.</b>	+45... LSE °C	+45°C
<b>tA</b>	<b>NO – NC alarm relay switching</b>	0= activates when alarm is on 1= deactivates when alarm is on	1
<b>AU</b>	<b>Auxiliary/alarm relay control</b>	0= alarm relay 1= manual auxiliary relay controlled via AUX key 2= automatic auxiliary relay managed by StA temp. setting with 2°C differential 3= relay disabled / TeleNET function 4= pump down function (see CHAP 5.15) 5= free voltage contact for condensing unit (AUX relay and compressor relay in parallel) 6= Contact for casing element control (AUX relay closed with compressor output inactive). 7= relay disabled / Modbus-RTU function	0
<b>StA</b>	<b>Temp. setting for aux. relay</b>	-45...+45°C	0
<b>In1</b>	<b>Man in cold room alarm</b> Select input INP1 on the board as <i>compressor protection alarm</i> or as <i>man in cold room alarm</i> (contact NC).	0 = compressor protection 1 = man in room alarm	0

<b>P1</b>	<b>Password type of protection</b> ( active when PA is not equal 0)	0 = only display set point 1= display set point, AUX, light access 2= access in programming not permitted 3= access in second level programming not permitted	3
<b>PA</b>	<b>Password</b> (see P1 for the type of protection)	0...999 0 = not active	0
<b>reL</b>	<b>Software release</b>	indicates software version	7 (Read only)

**SWITCHING ON THE ECP200 EXPERT ELECTRONIC CONTROLLER**

**5.11**

After wiring the electronic controller correctly, power up at 230 V AC; the display panel will immediately emit a beep and all the LEDs will come on simultaneously for a few seconds.

**COMPRESSOR ACTIVATION/DEACTIVATION CONDITIONS**

**5.12**

The **ECP200 EXPERT** controller activates the compressor when cold room temperature exceeds setting+differential (r0); it deactivates the compressor when cold room temperature is lower than the setting.

**MANUAL DEFROSTING**

**5.13**

To defrost just press the dedicated key (see section 5.2) to activate the elements relay. Defrosting will not take place if the end-of-defrost temperature setting (d2) is lower than the temperature detected by the evaporator sensor. Defrosting ends when the end-of-defrost temperature (d2) or maximum defrost time (d3) is reached.

**5.14*****HOT GAS DEFROSTING***

Set parameter d1 =1 to defrost in cycle inversion mode.

The compressor relay and defrost relay are activated throughout the defrost phase.

To ensure proper control of the system the installer must use the defrost output: this must allow opening of the cycle inversion solenoid valve and closure of the liquid solenoid valve. For capillary systems (without thermostat valve) it is only necessary to control the cycle inversion solenoid valve via the defrost relay control.

**5.15*****PUMP DOWN FUNCTION***

Pump down function is activated when parameter AU=4.

Connect pump down pressostat on the digital input 1-3 . The compressor is directly controlled by pressostat.

Connect evaporator solenoid valve on the AUX relay. The solenoid is controlled directly by thermostat.

**5.16*****PASSWORD FUNCTION***

When parameter PA is setting with value different to 0 the protection function is activated.

See parameter P1 for the different protection.

When PA is setting the protection start after two minutes of inactivity. On display appear 000. With up/down modify the number, with set key confirm it.

Use universal number 100 if you don't remember the password.



# CHAPTER 6: OPTIONAL KIT

## TeleNET MONITORING/SUPERVISION SYSTEM

6.1

For **TeleNET** connections to enable RS485 as indicated at chapter 6.3 and follow the scheme below. Refer to **TeleNET** user manual for instrument configuration.  
**WARNING:** During configuration, at entry "Module" to select the entry "Instrument ECP Base Series / ECP Expert Series".

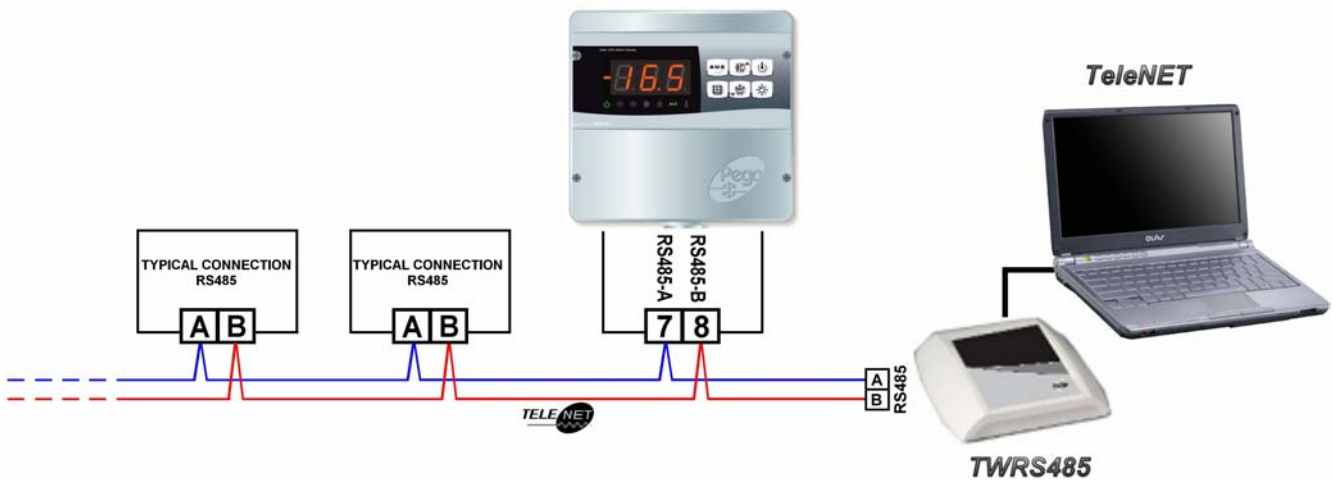

## NET CONFIGURATION WITH MODBUS-RTU PROTOCOL

6.2

For **RS485** connections with **Modbus-RTU** protocol, to enable RS485 output as indicated at chapter 6.3 and follow the scheme below.  
 Refer to MODBUS-RTU\_ECP200T1 user manual (available on Pego Internet web site) for MODBUS-RTU communication protocol specification.

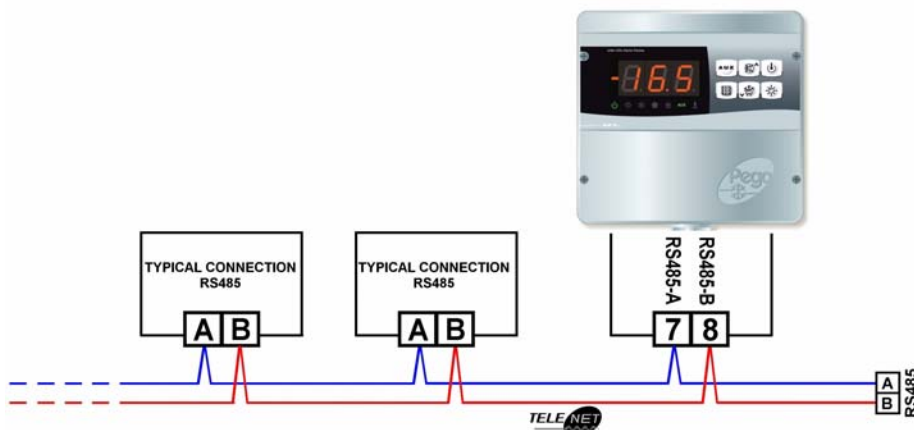

## 6.3

## ALARM RELAY / RS485 SWITCHING

Open the front of the box as described in Chap. 2.3 (page 6): rotate it downwards 180° to gain access to the electronic board

Undo the 6 CPU board fixing screws: remove the board from the frontal part of the box in ABS.

Configure the jumper from JUMPER JP2 (placed on the front of electrical board near the display far down on the right) following one of the ensuing options.

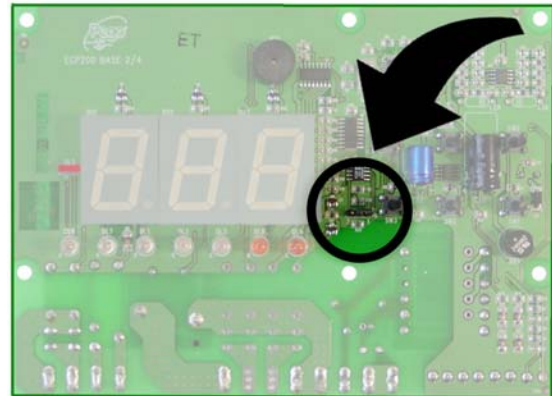
**RS485 output selection:**

Insert the jumper JP2 on 3-2 position and set the 2<sup>nd</sup> level variable

**AU=3 (TeleNET)**

or

**AU=7 (Modbus-RTU).**

The connection clamps are RS485\_(A) and RS485\_(B) on board of electrical board. Remember besides to assign an univocal net address in the current instruments net. (Ad 2<sup>nd</sup> level parameter).

Warning! with this configuration auxiliary relay is disabled.

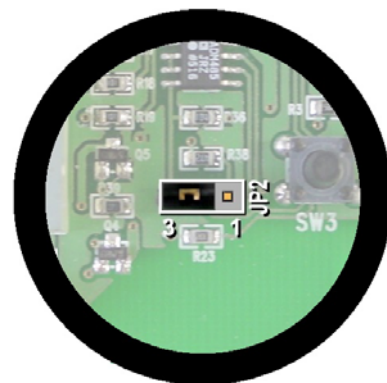
**AUX/Alarm relay selection:**

Insert the jumper JP2 in 2-1 position and set the 2<sup>nd</sup> level variable AU to a value different from 3 and 7 according to the needed function. Clamps of configurable relay clean contact are on AUX/ALL output, on board of electronic board. Warning! with this configuration RS485 connection is disabled.

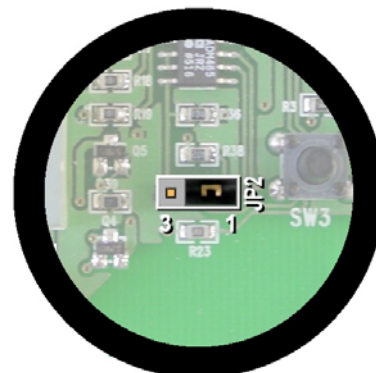

# CHAPTER 7: TROUBLESHOOTING

## TROUBLESHOOTING

### 7.1

In the event of any anomalies the ECP200 BASE warns the operator by displaying alarm codes and sounding the warning buzzer inside the control panel. If an alarm is tripped the display will show one of the following messages.

ALARM CODE	POSSIBLE CAUSE	SOLUTION
<b>E0</b>	<i>Cold room temperature sensor not working properly</i>	<ul style="list-style-type: none"> <li>• Check that cold room temperature sensor is working properly</li> <li>• If the problem persists replace the sensor</li> </ul>
<b>E1</b>	<i>Defrost sensor not working properly</i> (In this case defrosts will last time d3)	<ul style="list-style-type: none"> <li>• Check that defrost sensor is working properly</li> <li>• If the problems persists replace the sensor</li> </ul>
<b>E2</b>	<i>Eeprom alarm</i> An EEPROM memory alarm has been detected (All outputs except the alarm one are deactivated)	<ul style="list-style-type: none"> <li>• Switch unit off and back on</li> </ul>
<b>E8</b>	<i>Man in cold room alarm</i>	<ul style="list-style-type: none"> <li>• Reset the alarm input inside the cold room</li> </ul>
<b>Ec</b>	<i>Compressor protection tripped</i> (e.g. thermal protection or max pressure switch) (All outputs except the alarm one – where applicable – are deactivated)	<ul style="list-style-type: none"> <li>• Check that compressor is working properly</li> <li>• Check compressor absorption</li> <li>• If the problem persists contact the technical assistance service</li> </ul>
<b>Ed</b>	<i>Open door Alarm.</i> When the door is opened and after tdo time, it's setted back the normal functioning giving door open alarm (Ed)	<ul style="list-style-type: none"> <li>• Check door switch status</li> <li>• Check door switch connections</li> <li>• If the problem persists contact the technical assistance service</li> </ul>
<b>Temperature shown on display is flashing</b>	<i>Minimum or maximum temperature alarm.</i> The temperature inside the cold room has exceeded the min. or max. temperature alarm setting (see variables A1 and A2, user programming level)	<ul style="list-style-type: none"> <li>• Check that the compressor is working properly.</li> <li>• Sensor not reading temperature properly or compressor start/stop control not working.</li> </ul>

# APPENDICES

## A.1

### EC declaration of conformity

#### COSTRUTTORE / MANUFACTURER



PEGO S.r.l. Via Piacentina, 6/b 45030 Occhiobello (RO) – Italy –  
Tel. (+39) 0425 762906 Fax. (+39) 0425 762905

#### DENOMINAZIONE DEL PRODOTTO / NAME OF THE PRODUCT

MOD.: ECP200 BASE 2 - ECP200 BASE 2 A - ECP200 BASE 4 - ECP200 BASE 4 A

**IL PRODOTTO E' CONFORME ALLE SEGUENTI DIRETTIVE CE/THE PRODUCT IS IN CONFORMITY WITH THE REQUIREMENTS OF THE FOLLOWING EUROPEAN DIRECTIVES:**

2006/95/CE	Direttiva del Consiglio per l'unificazione delle normative dei Paesi CEE relativa al materiale elettrico destinato ad essere utilizzato entro certi limiti di tensione e successive modificazioni
2006/95/EC	Concil Directive on the approximation of the laws of the Member States relating to electrical equipments employed within certain limits of tension and following modifications
2004/108/CE	Direttiva del Consiglio per l'unificazione delle normative dei Paesi CEE relativa alla compatibilità elettromagnetica e successive modificazioni
2004/108/EC	Concil Directive on the approximation of the laws of the Member States relating to the electro-magnetical compatibility and following modifications
93/68 CEE	Direttiva del consiglio per la marcatura CE del materiale elettrico destinato ad essere utilizzato entro taluni limiti di tensione.
93/68 EEC	Council Directive for the CE marking of electrical materials to be used within certain limits of voltage

**LA CONFORMITA' PRESCRITTA DALLE DIRETTIVE E' GARANTITA DALL' ADEMPIMENTO A TUTTI GLI EFFETTI DELLE SEGUENTI NORME:  
CONFORMITY WITH THE REQUIREMENTS OF THIS DIRECTIVE IS TESTIFIED BY COMPLETE ADHRENCE TO THE FOLLOWING STANDARDS:**

#### NORME ARMONIZZATE / HARMONIZED EUROPEAN STANDARDS

**EN 61000-6-1**    **EN 61000-6-3**    **EN 60730-1**    **EN 60730-2-9**  
II Edition                      II Edition

Paolo Pegorari

ECP200 BASE4 WIRING DIAGRAM

A.2

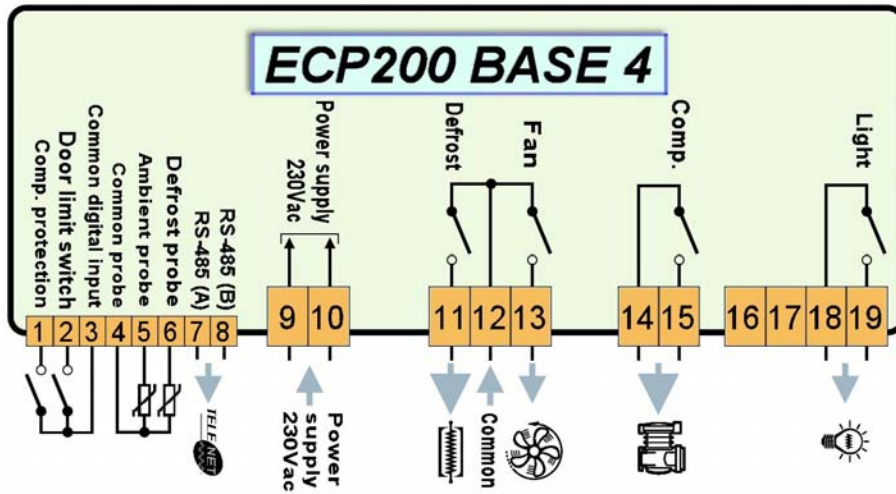

Voltage free contact

ECP200 BASE4A WIRING DIAGRAM

A.3

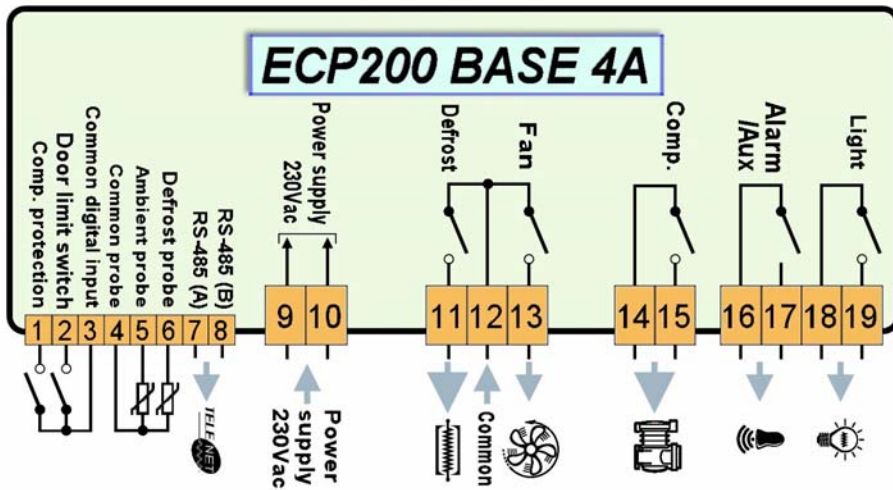

Optional  
(See option  
chapter)

Voltage free contact

A.4

ECP200 BASE2 WIRING DIAGRAM

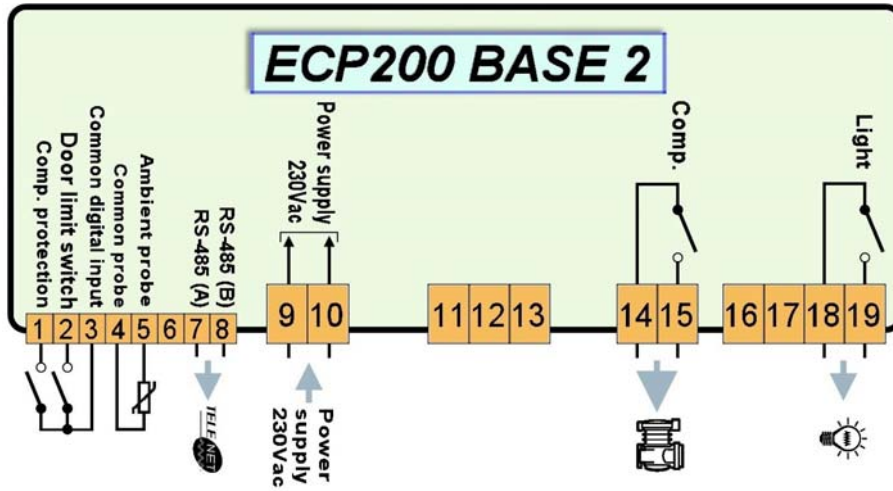

**Voltage free contact**

A.5

ECP200 BASE2A WIRING DIAGRAM

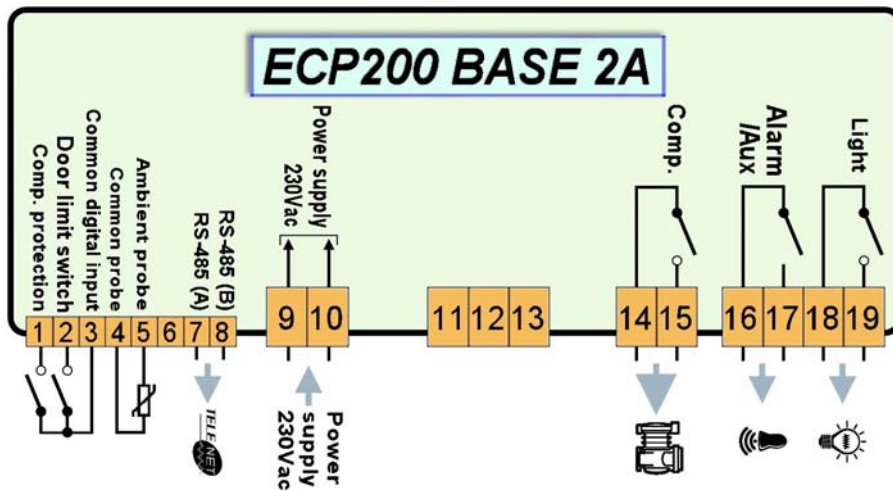

*Optional  
(See option  
chapter)*

**Voltage free contact**



CONNECTION EXAMPLE (1) - ECP200 BASE4 /BASE4A

A.6

Connection with outputs powered for direct control of functions.

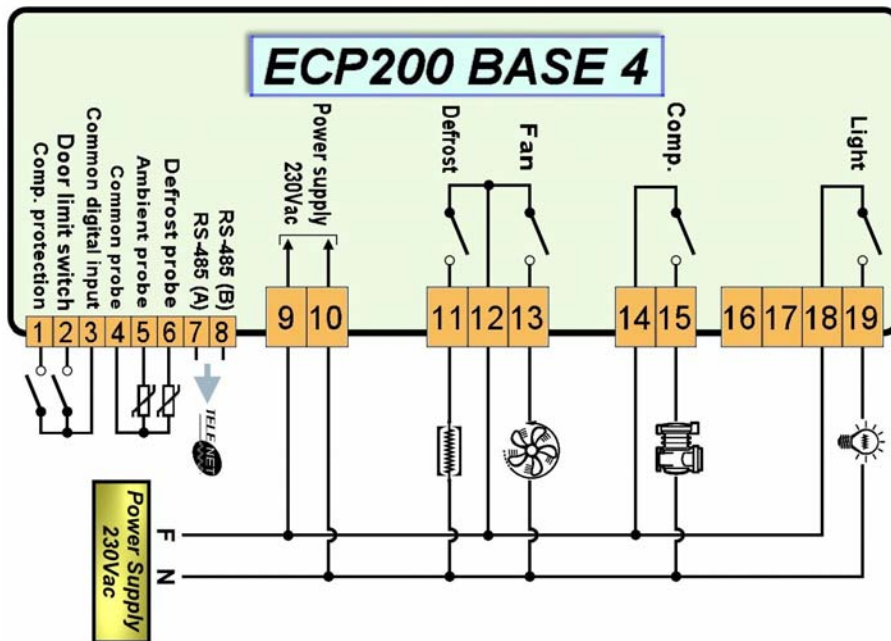

CONNECTION EXAMPLE (2) - ECP200 BASE4 /BASE4A

A.7

Mixed connection with on/off contact to enable towards condensing unit power board and fan, light and defrost outputs powered for direct control.

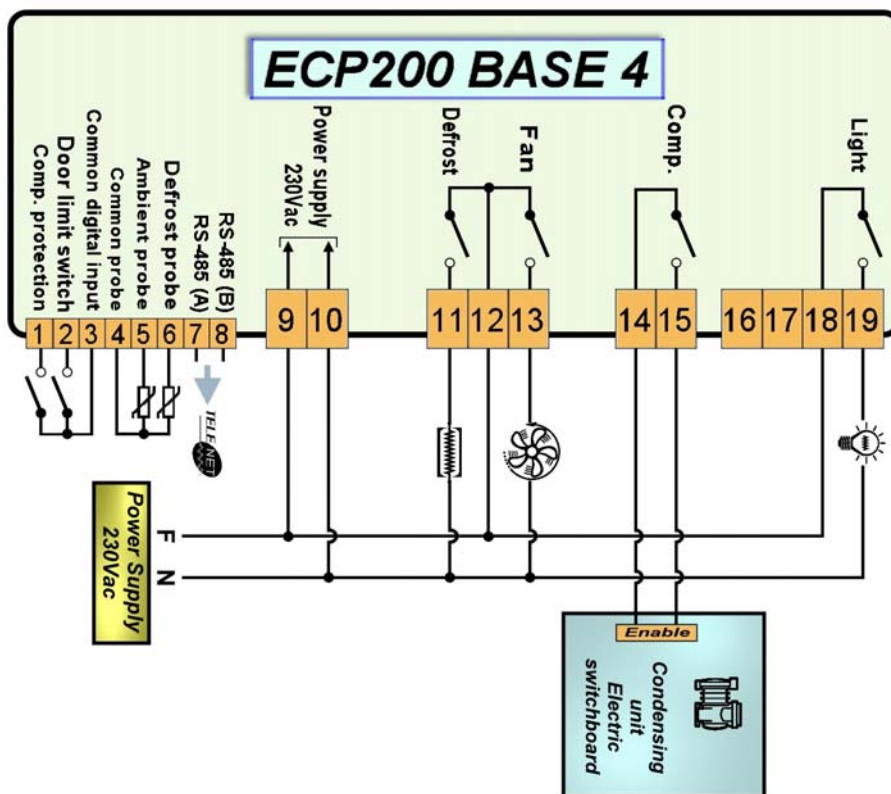

A.8

CONNECTION EXAMPLE (3) - ECP200 BASE2 /BASE2A

Connection with outputs powered for direct control of functions.

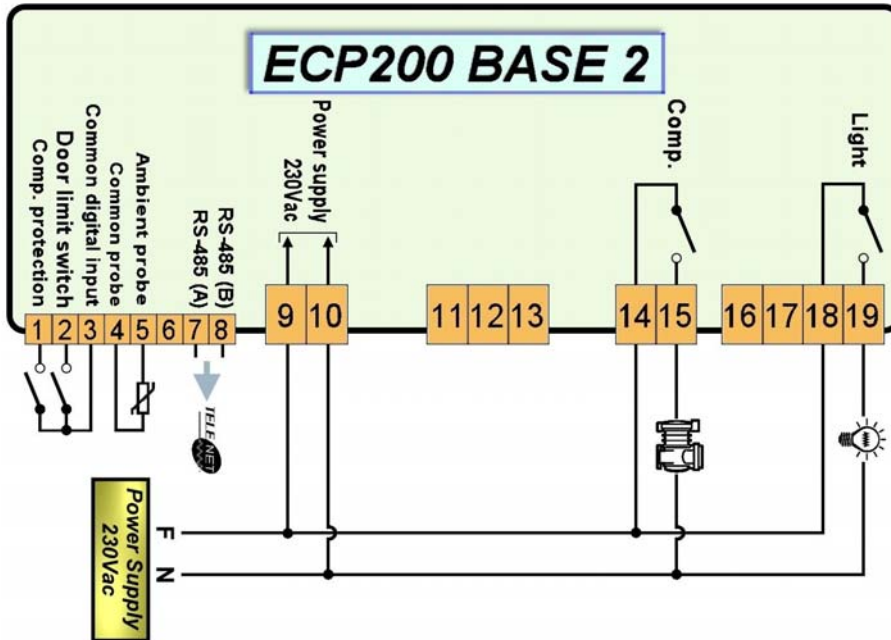

A.9

CONNECTION EXAMPLE (4) - ECP200 BASE2 /BASE2A

Mixed connection with on/off contact powered to enable towards room power board and light output powered for direct control.

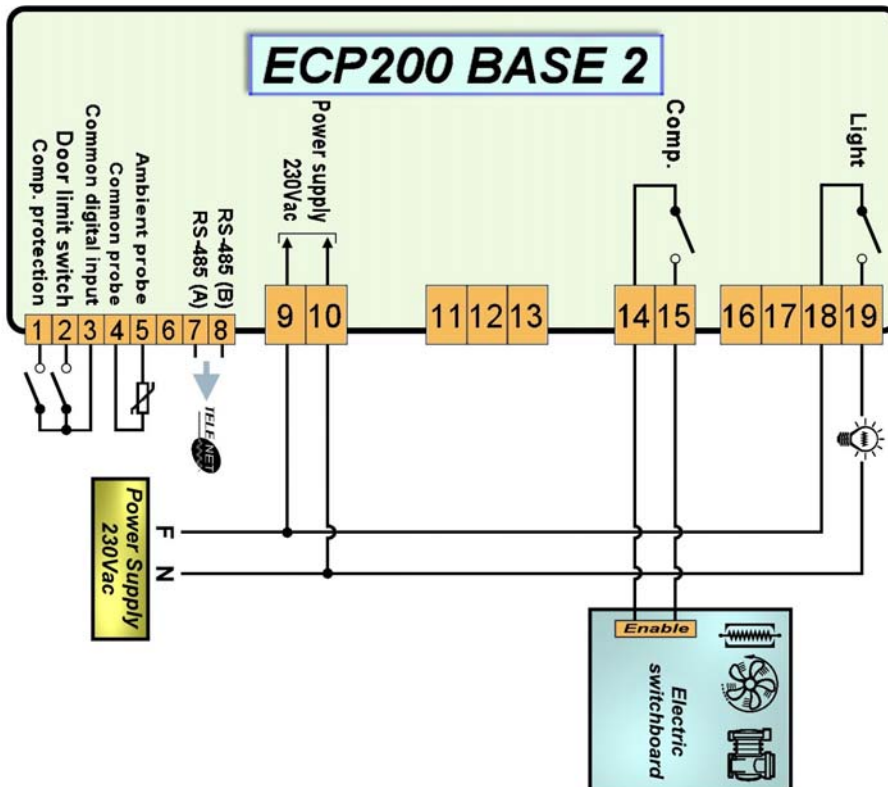











**PEGO S.r.l.**

**Via Piacentina, 6/b**

**45030 OCCHIOBELLO –ROVIGO-**

**Tel : 0425 762906**

**Fax: 0425 762905**

**[www.peggo.it](http://www.peggo.it)**

**e-mail: [info@peggo.it](mailto:info@peggo.it)**

Distributor: