

SC10CLX LBP/MBP Compressor R404A/R507 220-240V 50/60Hz

General

| | |
|-----------------------|----------------------|
| Code number | 104L2533 |
| Approvals | EN 60335-2-34, UL984 |
| Compressors on pallet | 80 |

Application

| Application | LBP/MBP | | | |
|--|---------|-----------|-----------|--|
| Frequency | Hz | 50 | 60 | |
| Evaporating temperature | °C | -35 to 5 | -35 to -5 | |
| Voltage range | V | 198 - 254 | 198 - 254 | |
| Max. condensing temperature continuous (short) | °C | 50 (60) | 50 (60) | |
| Max. winding temperature continuous (short) | °C | 125 (135) | 125 (135) | |

Cooling requirements

| Frequency | Hz | 50 | | | 60 | | |
|-------------------------|----|----------------|----------------|-----|----------------|----------------|-----|
| Application | | LBP | MBP | HBP | LBP | MBP | HBP |
| 32°C | | F ₂ | F ₂ | - | F ₂ | F ₂ | - |
| 38°C | | F ₂ | F ₂ | - | F ₂ | F ₂ | - |
| 43°C | | - | - | - | - | - | - |
| Remarks on application: | | | | | | | |

Motor

| Motor type | CSIR | | |
|---|------|------|------|
| LRA (rated after 4 sec. UL984), HST LST | A | 14.8 | - |
| Cut in Current, HST LST | A | 14.8 | - |
| Resistance, main start winding (25°C) | Ω | 5.0 | 13.7 |

Design

| | | |
|-------------------------------------|-----------------|-------------------|
| Displacement | cm ³ | 10.29 |
| Oil quantity (type) | cm ³ | 550 (polyolester) |
| Maximum refrigerant charge | g | 1300 |
| Free gas volume in compressor | cm ³ | 1460 |
| Weight without electrical equipment | kg | 13.1 |

Dimensions

| | | | |
|----------------------|--------------------------|--------------------------|-----------|
| Height | mm | A | 209 |
| | | B | 203 |
| | | B1 | 183 |
| | | B2 | 100 |
| Suction connector | location/I.D. mm angle | C | 8.2 37° |
| | material comment | Cu-plated steel Al cap | |
| Process connector | location/I.D. mm angle | D | 6.2 37° |
| | material comment | Cu-plated steel Al cap | |
| Discharge connector | location/I.D. mm angle | E | 6.2 37° |
| | material comment | Cu-plated steel Al cap | |
| Oil cooler connector | location/I.D. mm angle | F | - |
| | material comment | - | |
| Connector tolerance | I.D. mm | ±0.09 | |
| Remarks: | | | |

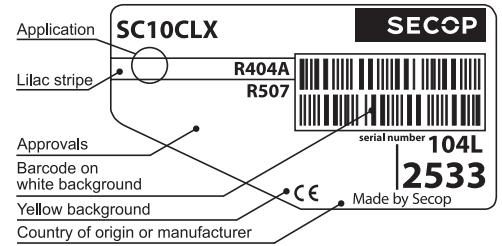

- S = Static cooling normally sufficient
- O = Oil cooling
- F₁ = Fan cooling 1.5 m/s (compressor compartment temperature equal to ambient temperature)
- F₂ = Fan cooling 3.0 m/s necessary
- SG = Suction gas cooling normally sufficient
- = not applicable in this area

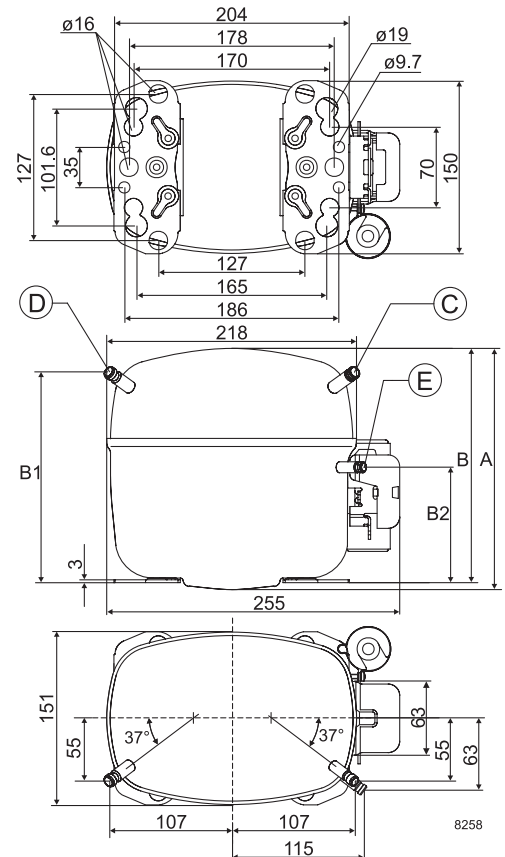

ASHRAE LBP*

 230V, 60Hz, fan cooling F₂

| | | | | | | | | | | | | | | | | | |
|--------------------|-----|-----|------|------|------|-------|------|------|------|------|------|---|---|-----|----|----|----|
| Evap. temp. in °C | -45 | -40 | -35 | -30 | -25 | -23.3 | -20 | -15 | -10 | -6.7 | -5 | 0 | 5 | 7.2 | 10 | 15 | 20 |
| Capacity in W | | | 274 | 399 | 537 | 587 | 690 | 862 | 1057 | 1200 | 1279 | | | | | | |
| Power cons. in W | | | 312 | 374 | 430 | 449 | 487 | 547 | 617 | 670 | 700 | | | | | | |
| Current cons. in A | | | 2.21 | 2.37 | 2.55 | 2.62 | 2.76 | 3.00 | 3.27 | 3.46 | 3.57 | | | | | | |
| COP in W/W | | | 0.88 | 1.07 | 1.25 | 1.31 | 1.42 | 1.57 | 1.71 | 1.79 | 1.83 | | | | | | |

ASHRAE LBP*

 220V, 50Hz, fan cooling F₂

| | | | | | | | | | | | | | | | | | |
|--------------------|-----|-----|------|------|------|-------|------|------|------|------|------|------|------|-----|----|----|----|
| Evap. temp. in °C | -45 | -40 | -35 | -30 | -25 | -23.3 | -20 | -15 | -10 | -6.7 | -5 | 0 | 5 | 7.2 | 10 | 15 | 20 |
| Capacity in W | | | 202 | 306 | 428 | 474 | 571 | 738 | 930 | 1071 | 1149 | 1399 | 1682 | | | | |
| Power cons. in W | | | 260 | 304 | 353 | 370 | 404 | 455 | 503 | 533 | 548 | 585 | 614 | | | | |
| Current cons. in A | | | 2.01 | 2.16 | 2.32 | 2.38 | 2.50 | 2.70 | 2.92 | 3.08 | 3.16 | 3.42 | 3.69 | | | | |
| COP in W/W | | | 0.78 | 1.01 | 1.21 | 1.28 | 1.42 | 1.62 | 1.85 | 2.01 | 2.10 | 2.39 | 2.74 | | | | |

EN 12900 Household (CECOMAF)

 230V, 60Hz, fan cooling F₂

| | | | | | | | | | | | | | | | | | |
|--------------------|-----|-----|------|------|------|-------|------|------|------|------|------|---|---|-----|----|----|----|
| Evap. temp. in °C | -45 | -40 | -35 | -30 | -25 | -23.3 | -20 | -15 | -10 | -6.7 | -5 | 0 | 5 | 7.2 | 10 | 15 | 20 |
| Capacity in W | | | 224 | 335 | 455 | 499 | 588 | 738 | 906 | 1028 | 1096 | | | | | | |
| Power cons. in W | | | 304 | 370 | 430 | 450 | 489 | 552 | 623 | 677 | 707 | | | | | | |
| Current cons. in A | | | 2.19 | 2.36 | 2.55 | 2.62 | 2.77 | 3.02 | 3.30 | 3.50 | 3.61 | | | | | | |
| COP in W/W | | | 0.74 | 0.90 | 1.06 | 1.11 | 1.20 | 1.34 | 1.45 | 1.52 | 1.55 | | | | | | |

EN 12900 Household (CECOMAF)

 220V, 50Hz, fan cooling F₂

| | | | | | | | | | | | | | | | | | |
|--------------------|-----|-----|------|------|------|-------|------|------|------|------|------|------|------|-----|----|----|----|
| Evap. temp. in °C | -45 | -40 | -35 | -30 | -25 | -23.3 | -20 | -15 | -10 | -6.7 | -5 | 0 | 5 | 7.2 | 10 | 15 | 20 |
| Capacity in W | | | 166 | 255 | 360 | 400 | 483 | 625 | 789 | 910 | 977 | 1190 | 1430 | | | | |
| Power cons. in W | | | 258 | 302 | 352 | 369 | 404 | 457 | 508 | 540 | 556 | 597 | 631 | | | | |
| Current cons. in A | | | 2.00 | 2.15 | 2.32 | 2.38 | 2.51 | 2.72 | 2.94 | 3.10 | 3.19 | 3.45 | 3.73 | | | | |
| COP in W/W | | | 0.64 | 0.84 | 1.02 | 1.08 | 1.20 | 1.37 | 1.55 | 1.68 | 1.76 | 1.99 | 2.27 | | | | |

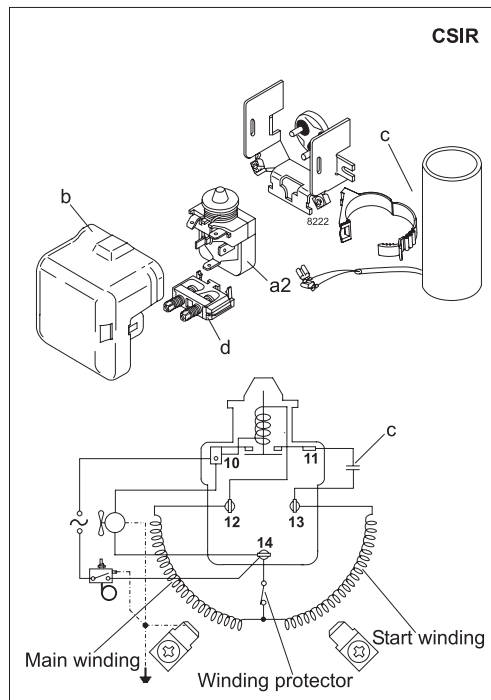

| Accessories for | SC10CLX | Figure | Code number | Test conditions | EN 12900/CECOMAF | ASHRAE LBP* |
|---------------------------|-------------------------|--------|-------------|-----------------------------|--------------------|-------------|
| PTC starting device | 6.3 mm spade connectors | a1 | - | Condensing temperature | 45°C | 43.3°C |
| | 4.8 mm spade connectors | | - | Ambient temperature | 32°C | 32°C |
| Starting relay | 6.3 mm spade connectors | a2 | 117U6005 | Suction gas temperature | 32°C | 32°C |
| Cover | | b | 103N2008 | Liquid temperature | no subcooling | 32°C |
| Start. capacitor 80 µF | 6.3 mm spade connectors | c | 117U5017 | | | |
| Cord relief | | d | 103N1004 | | | |
| Protection screen for PTC | | g | - | | | |
| | | | | Mounting accessories | Code number | |
| | | | | Bolt joint for one comp. | Ø: 16 mm | 118-1917 |
| | | | | Bolt joint in quantities | Ø: 16 mm | 118-1918 |
| | | | | Snap-on in quantities | Ø: 16 mm | 118-1919 |

Secop can accept no responsibility for possible errors in catalogues, brochures and other printed material. Secop reserves the right to alter its products without notice. This also applies to products already on order provided that such alterations can be made without consequential changes being necessary in specifications already agreed. All trademarks in this material are property of the respective companies. Secop and the Secop logotype are trademarks of Secop GmbH. All rights reserved. www.secop.com